

Specification

SMJPA3020120

SSC		Customer
Drawn	Approval	Approval

SMJPA3020120

SMJPA3020120



Description

Acrich 2 series designed for AC drive(or operation) doesn't need the converter which is essential for conventional general lighting. Also, its high power factor can show best energy saving effect in many lighting applications.

As there is no need of converter, Acrich 2 series can realize as close life-time as original LED and make a better use of a space in many applications.

Features

- Connect using a AIC directly to AC power
- High Power Efficiency
- High Power Factor
- Low THD
- Long Life Time
- Simplest BOM
- Miniaturization
- Lead Free product
- RoHS compliant

Applications

- Bulb light
- Down light
- Factory Ceiling light
- Industrial Light

* The appearance and specifications of the product can be changed for improvement without notice.

[Contents]

1. Outline dimensions -----	4
2. SMJPA3020120 Circuit configurations----	5
3. Characteristics of SMJPA3020120-----	6
4. Color spectrum -----	7
4. Power characteristics-----	7
5. Junction temperature characteristics-----	8
6. Radiation pattern -----	9
7. Binning structure -----	10
8. Tray packing-----	11
9. Precautions for use -----	12
10. Handling of silicone resin for LEDs-----	12

1. Outline dimensions

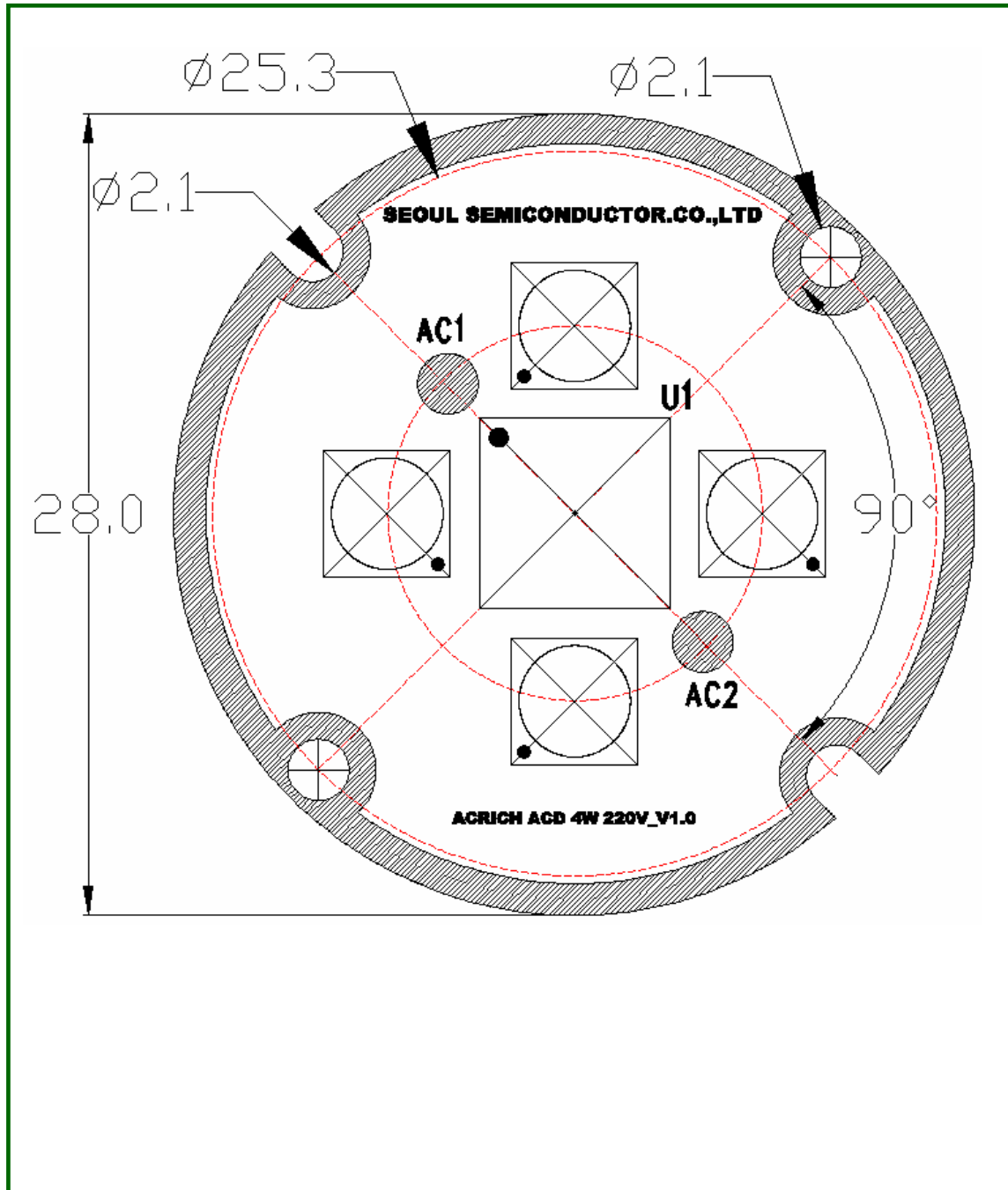

* Notes :

[1] All dimensions are in millimeters. (Tolerance : ± 0.2)

[2] Scale : none

[3] The appearance and specifications of the product may be changed for improvement without notice

2. SMJPA3020120 Circuit Configurations

Surge Protection Circuit

A metal oxide varistor (MOV) is often used to protect lighting systems from electrical surges and ring-wave effects, and help manufacturers meet safety and performance standards. The MOV prevents short-duration voltage impulse. Lightning tests (IEC 61000-4-5) and ring-wave Tests (IEEE C.62.41) can be used for these real-life threat simulation in the lab.

A surge protection circuit (SPC) consists of two components (MOV & fusible resistor) and it is not necessary for normal operation of the Acrich IC module.

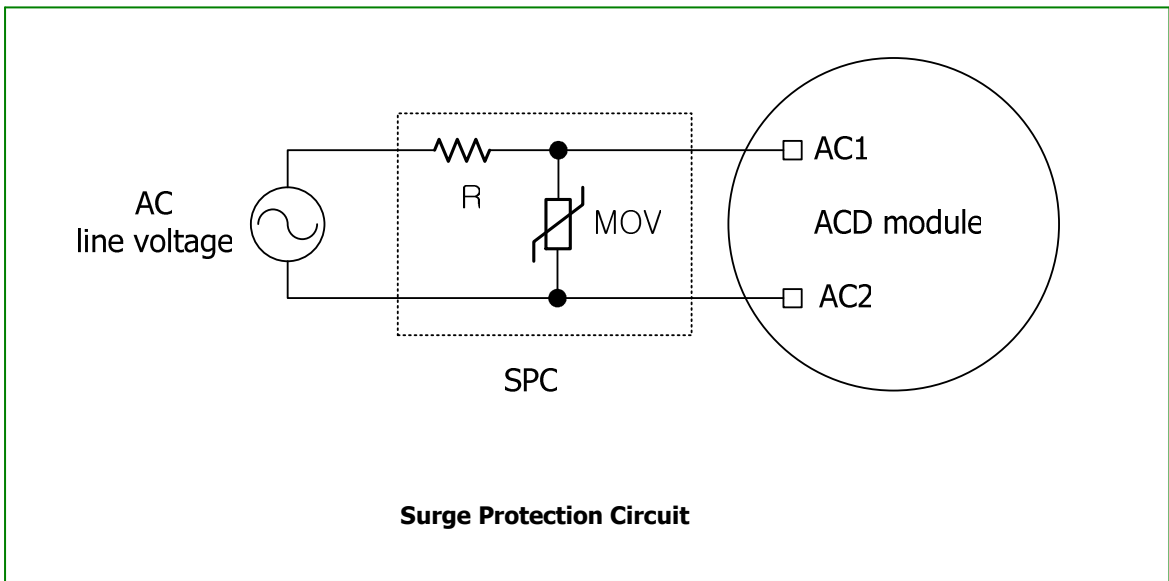

SPC Components Value

Voltage	Type	R	MOV
100V	4W module	22Ω. 5%. 1W	XXX-391D07 Or XXX-431D07
	8W module		
	12W module		
120V	4W module		
	8W module		
	12W module		
220V	4W module		
	8W module		
	12W module		

3. Characteristics of SMJPA3020120

1. Electro-Optical characteristics at 220V , Ta=25°C

Parameter	Symbol	Value			Unit
		Min	Typ	Max	
Luminous Flux [1]	Φ_V [2]	270	320	-	lm
Correlated Color Temperature [3]	CCT	2600	3000	3200	K
CRI	R _a	80	-	-	-
Operating Voltage [4]	V _{opt}	220/230/240			V[RMS]
Power Dissipation	P _D	-	4.7	-	W
Operating Frequency	Freq	50 / 60			Hz
Power Factor	PF	Over 0.95			-
View Angle	2 θ 1/2	120			deg.

1-2 Absolute Maximum Ratings

Parameter	Symbol	Value	Unit
Max. Voltage	V _{opt}	264	V[RMS]
Power Dissipation	P _d	5.7	W
Operating Temperature	T _{opr}	-30 ~ 85	°C
Storage Temperature	T _{stg}	-40 ~ 100	°C
ESD Sensitivity	-	± 4,000V HBM	-

* Notes :

- [1] Acrich 2 series maintain the tolerance of ±10% on flux and power measurements.
- [2] Φ_V is the total luminous flux output measured with an integrated sphere.
- [3] Correlated Color Temperature is derived from the CIE 1931 Chromaticity diagram.
- [4] 'Operating Voltage' doesn't indicate the maximum voltage which customers use but means tolerable voltage according to each country's voltage variation rate. It is recommended that the solder pad temperature should be below 70°C.

4. Color spectrum

Relative Spectral Power Distribution at Ta=25°C

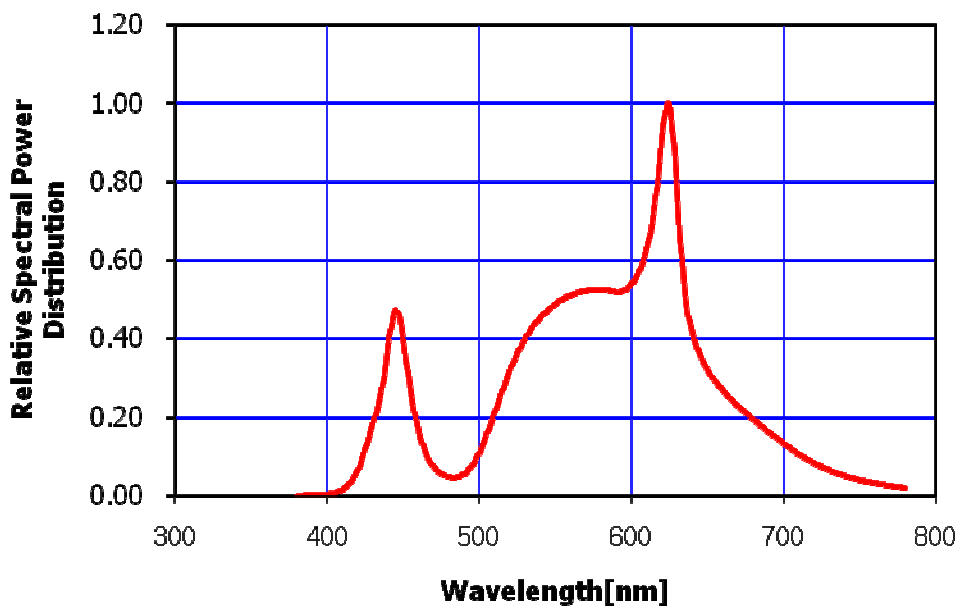

5. Power characteristic

Relative Power Distribution vs. Voltage at Ta=25°C

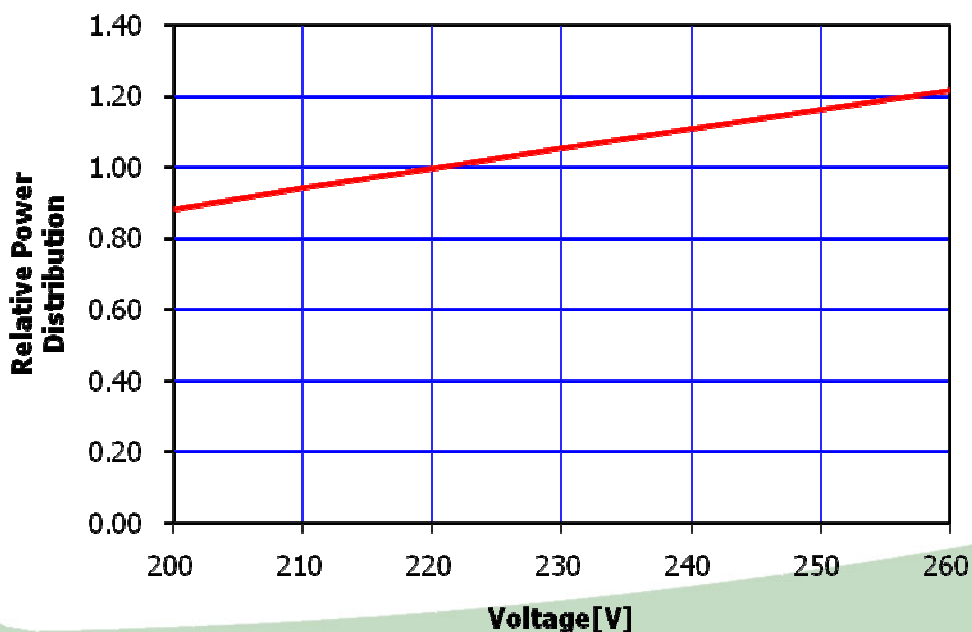

Relative Luminous flux vs. Forward Voltage, Ta=25°C

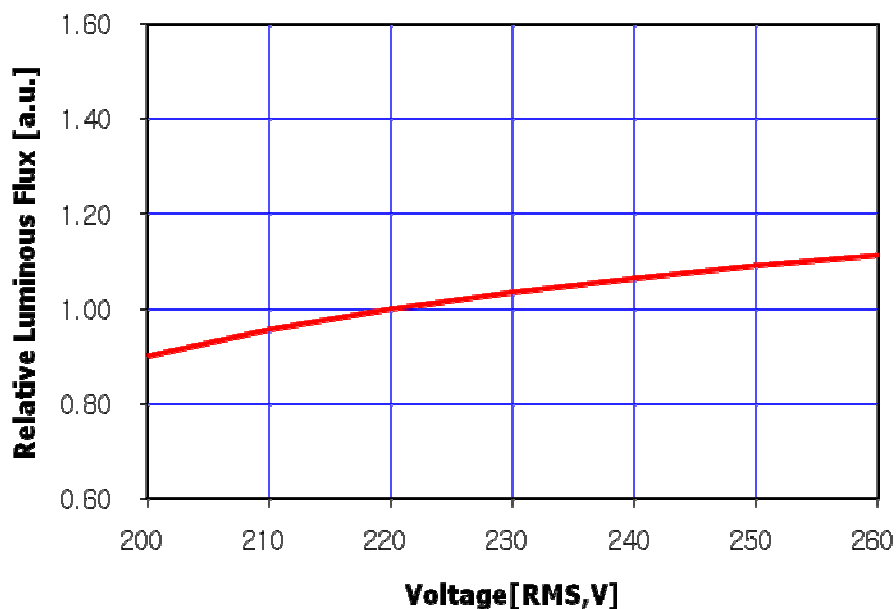

6. Junction Temperature Characteristics

Relative Luminous Flux [%] vs. Junction Temperature, 220 Voltage

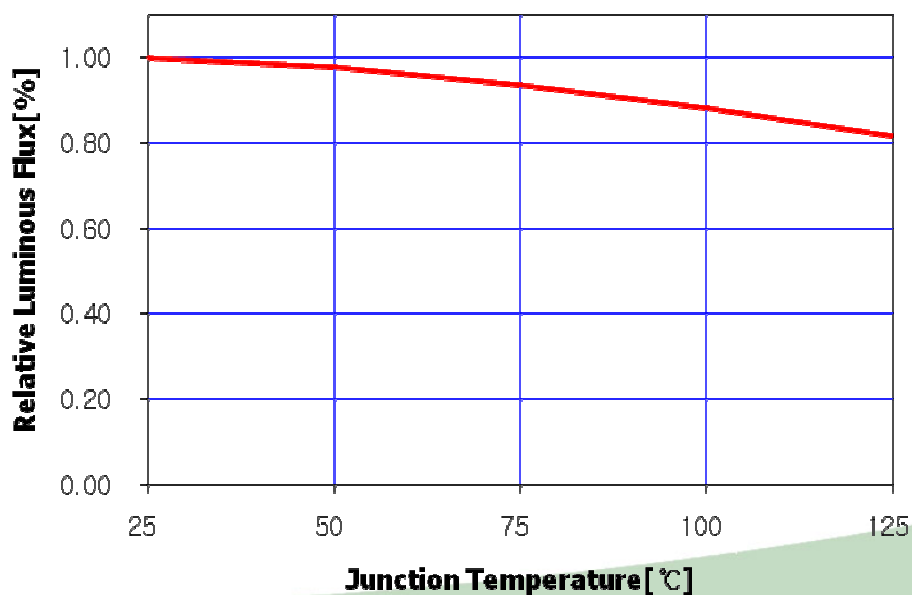

Relative CCT vs. Junction Temperature

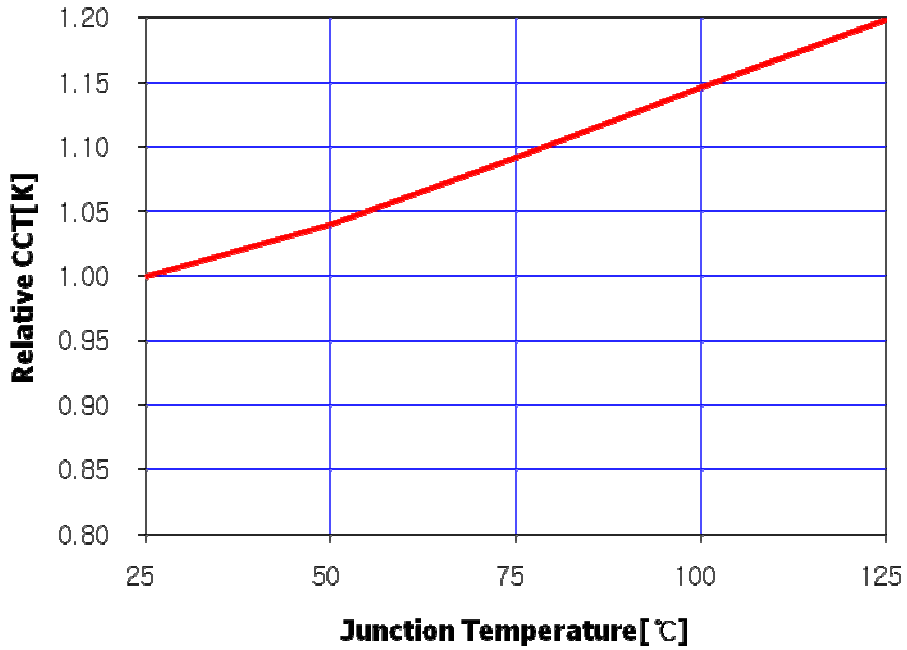

7. Radiation Pattern

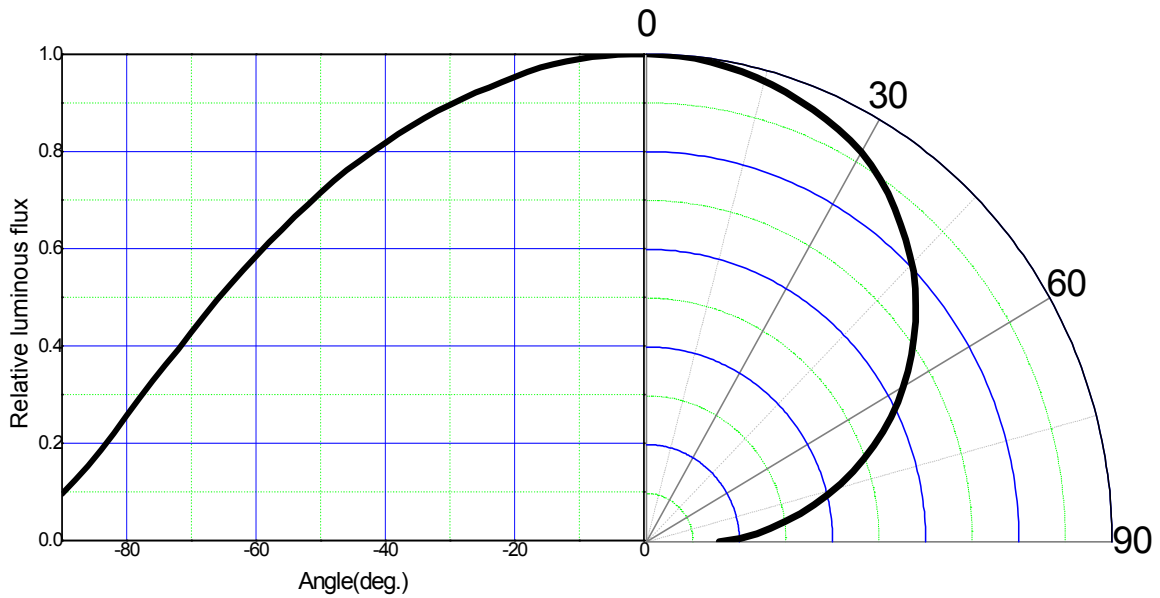

8. Binning Structure

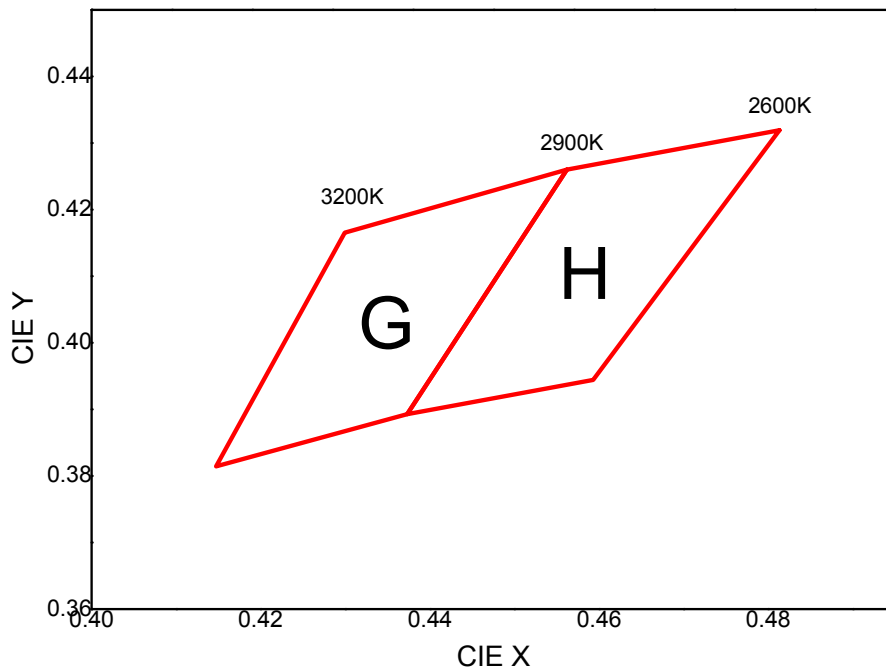

*Notes : For more detailed information on Acrich binning see the "Acrich Binning and Labeling" document at www.Acrich.com

9. Tray Packing

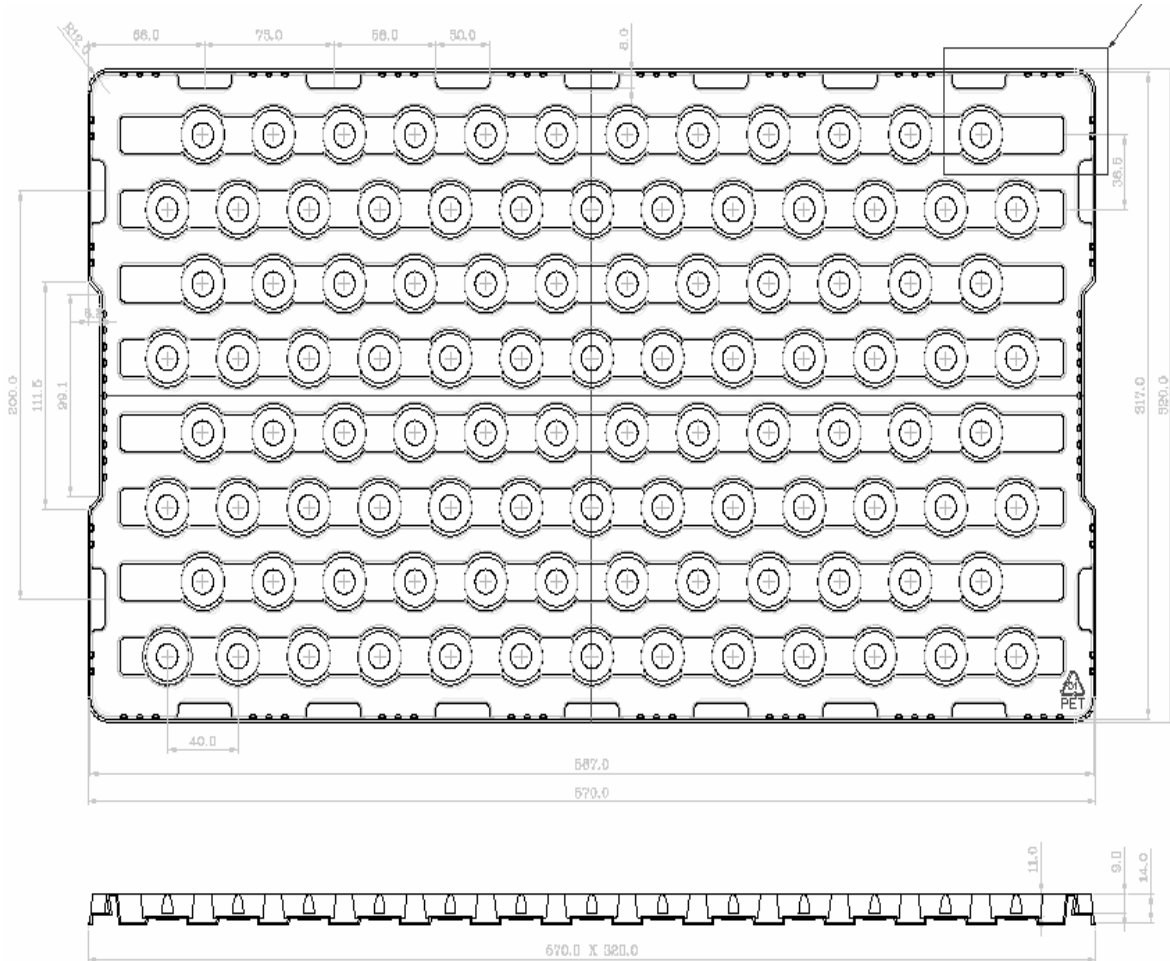

1Box = (100 PCS per tray) x 10 layer = 1000 PCS
about 6kgs

Box size(L x W x H) = 590 x 330 x 260

10. Precautions for use

- Please attach a varistor for protecting surge according to the application note
- Please attach a resistance according to the application note
- Please note Acrich runs on high voltage so use caution when near the leads or if a dome is inadvertently removed while circuit is active
- Please do not touch any of the circuit board, components or terminals with bare hands or metal while circuit is electrically active.
- Please do not add or change wires while Acrich circuit is active
- Please do not touch wire on solder pad at driving AC source
- The appearance and specifications of the product may be modified for improvement without notice.
- Long time exposure of sunlight or occasional UV exposure will cause lens discoloration.
- Attaching LEDs, do not use adhesives that outgas organic vapor.

11. Handling of silicone resin for LEDs

- Acrich series is encapsulated with silicone resin for high optical efficiency.
- Please do not touch the silicone resin area with sharp objects such as pincette(tweezers).
- Finger prints on silicone resin area may affect the performance.
- Please store LEDs in covered containers as it is dust sensitive.
- Excessive force more than 3000gf to the silicone lens can result in fatal or permanent damage with LEDs.
- Please do not cover the silicone resin area with any other resins such as epoxy, urethane, etc.