



Driving Indicator LEDs

LED Driver Roadmap

RGB LED

Programmable RGB LED

NJU6061
RGB LED Driver



RGBLED / 256-step / I2C IF

NJU6062
RGB LED Driver



RGBLED / 256-step / I2C IF

Internal RAM

NJU60XX
RGB LED Driver

White LED

PWM/8LEDs

NJU60XX
White LED Driver

Constant Current /1LED

NJU6080
White LED Driver



Constant Current /4LEDs

NJU60XX
White LED Driver



Constant Current /Multi LEDs

NJU60XX
White LED Driver

PLN

U.D

MP

RGB LED Driver Lineup

DEVICE	FUNCTION	APPLICATION	PACKAGE	STATUS
NJU6061	RGB LED Driver Internal 128 steps Program Function Cascade connection	Cellular phone Home Audio Backlight	SSOP14 FFP12	MP
NJU6062	RGB LED Driver 256 steps I2C I/F	Home Audio Car Audio Backlight	SSOP14 FFP12	MP



Functional Comparative Chart

	NJU6061	NJU6062
PWM	128 steps x 3 channels	256 steps x 4 channels
Step-up Circuit	NO	NO
Power Supply (Logic)	2.4 - 5.5V	1.8 - 5.5V
Power Supply (LED)	to 6.0V	to 6.0V
Operating Current	80uA (VDD=3V)	120 uA (VDD=3V)
External Components	Rx4	Rx4
LED Current	30mA x 3 channels	30mA x 4 channels
Operating Temp.	-40 - +85°C	-40 - +85°C
Package	SSOP14 (5.0x6.5x1.15mm)	SSOP14 (5.0x6.5x1.15mm)
Function	Program Function Cascade connection	Cascade connection
Interface	8bit serial	I²C

For cost saving, it is a conscious choice not to incorporate a voltage booster.

NJU6061 Block Diagram

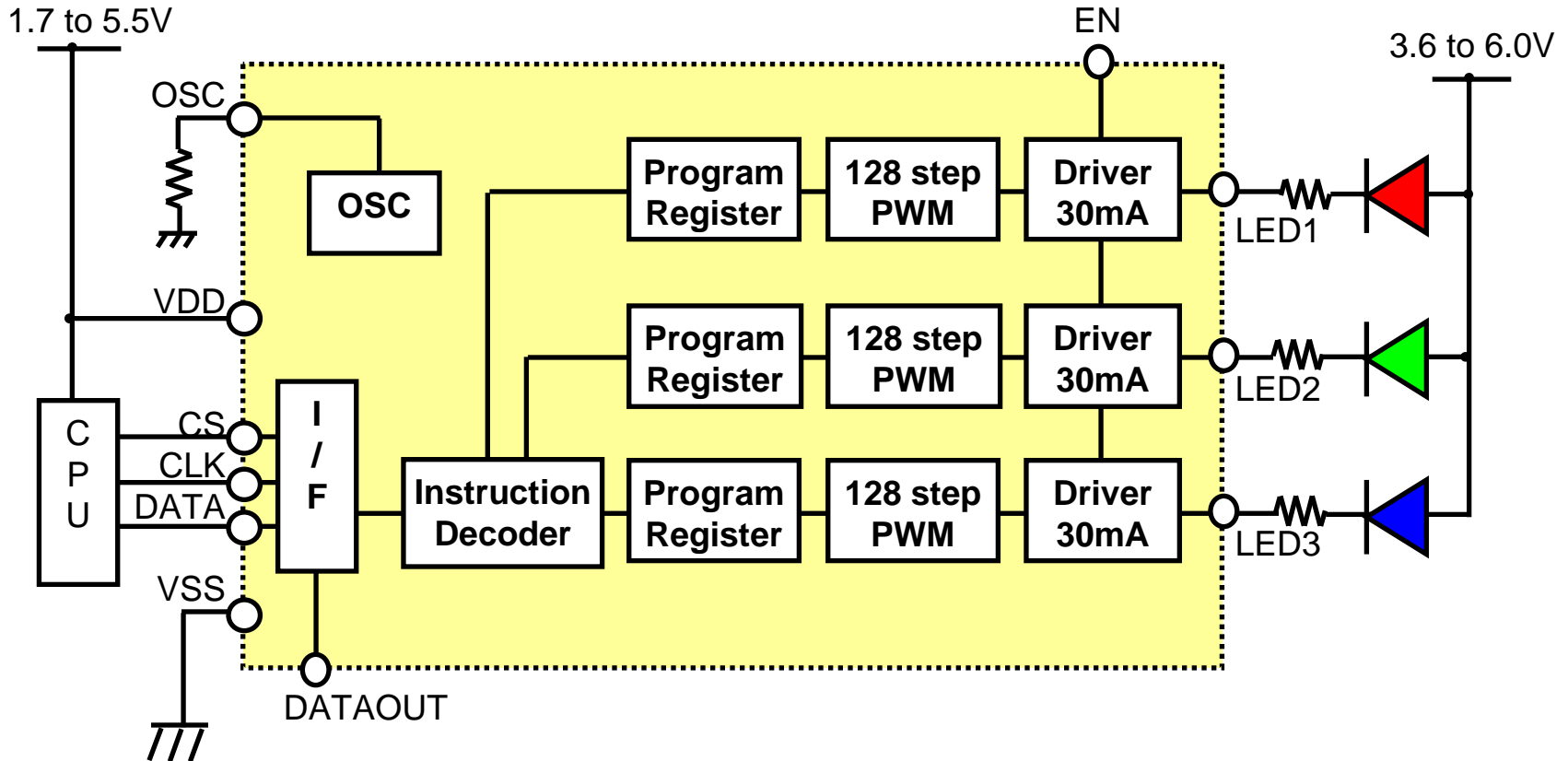

16 steps are selected from 128 steps PWM. And the nonlinear luminance characteristic of LED is rectified so that it becomes linear by appearance.

Programmable PWM Function

Realize Sweep function simply.
Light CPU Load.

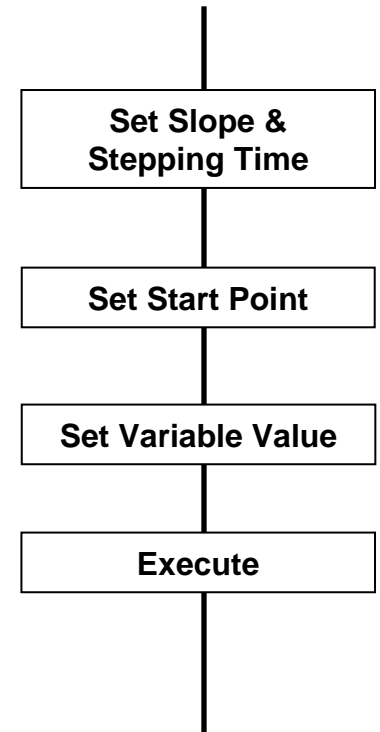
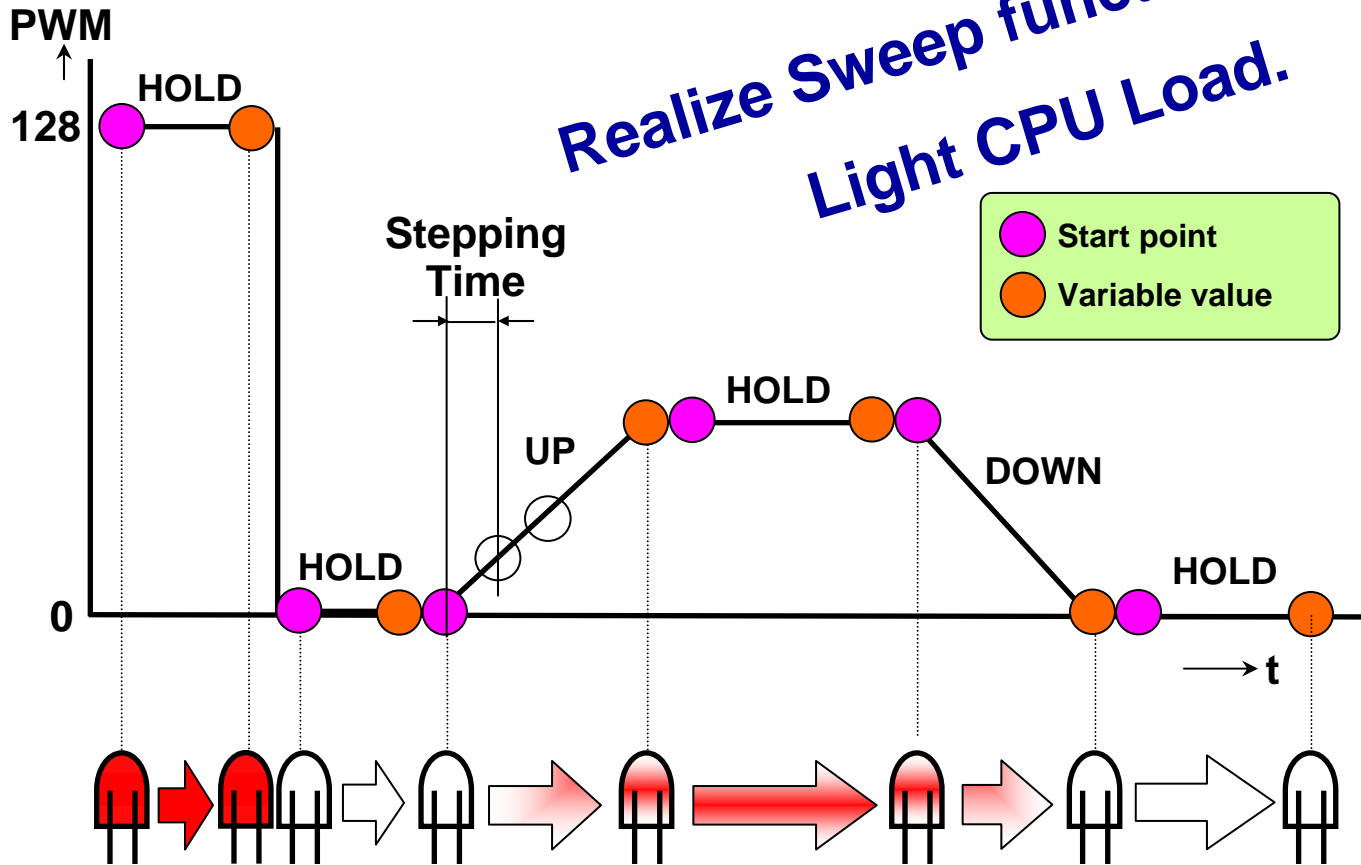

Benefits of RGB LED Driver

Conventional System

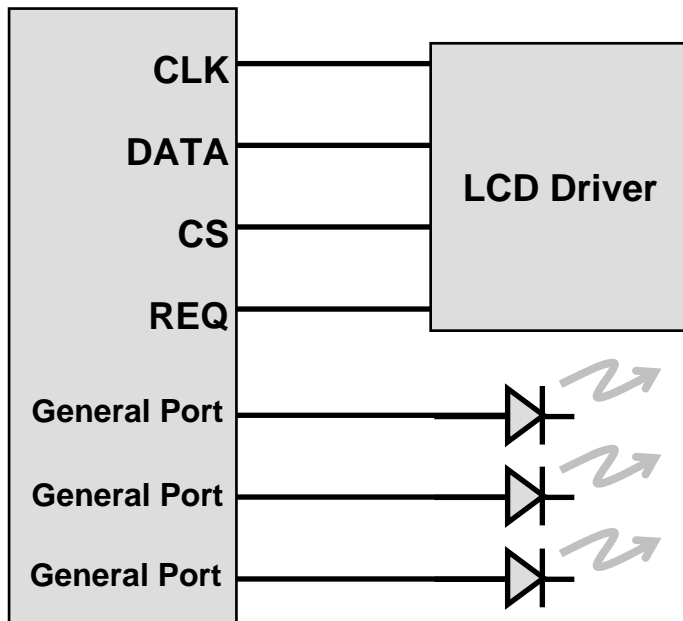

7 Colors
3 Ports Required
Heavy CPU Load

System using RGB LED Driver

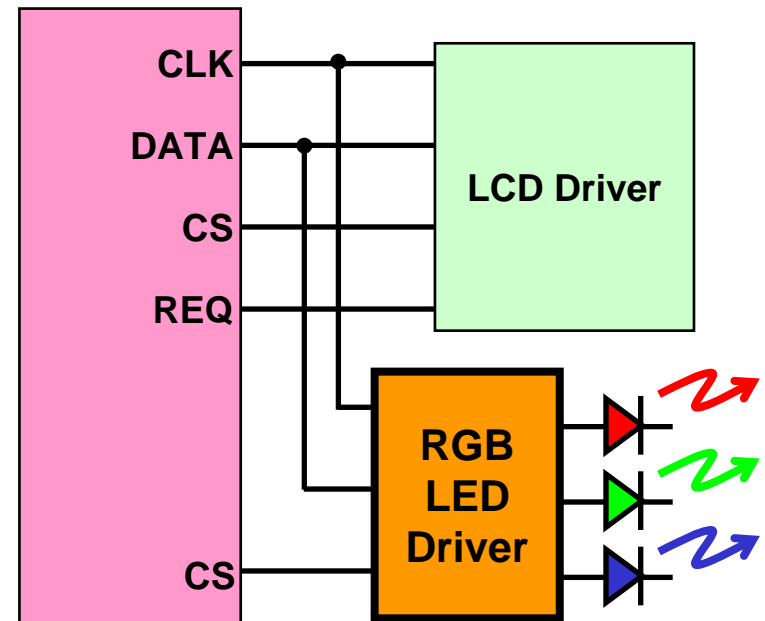

Full Color
Only 1 Port Required
Light CPU Load

NJU6062 Block Diagram

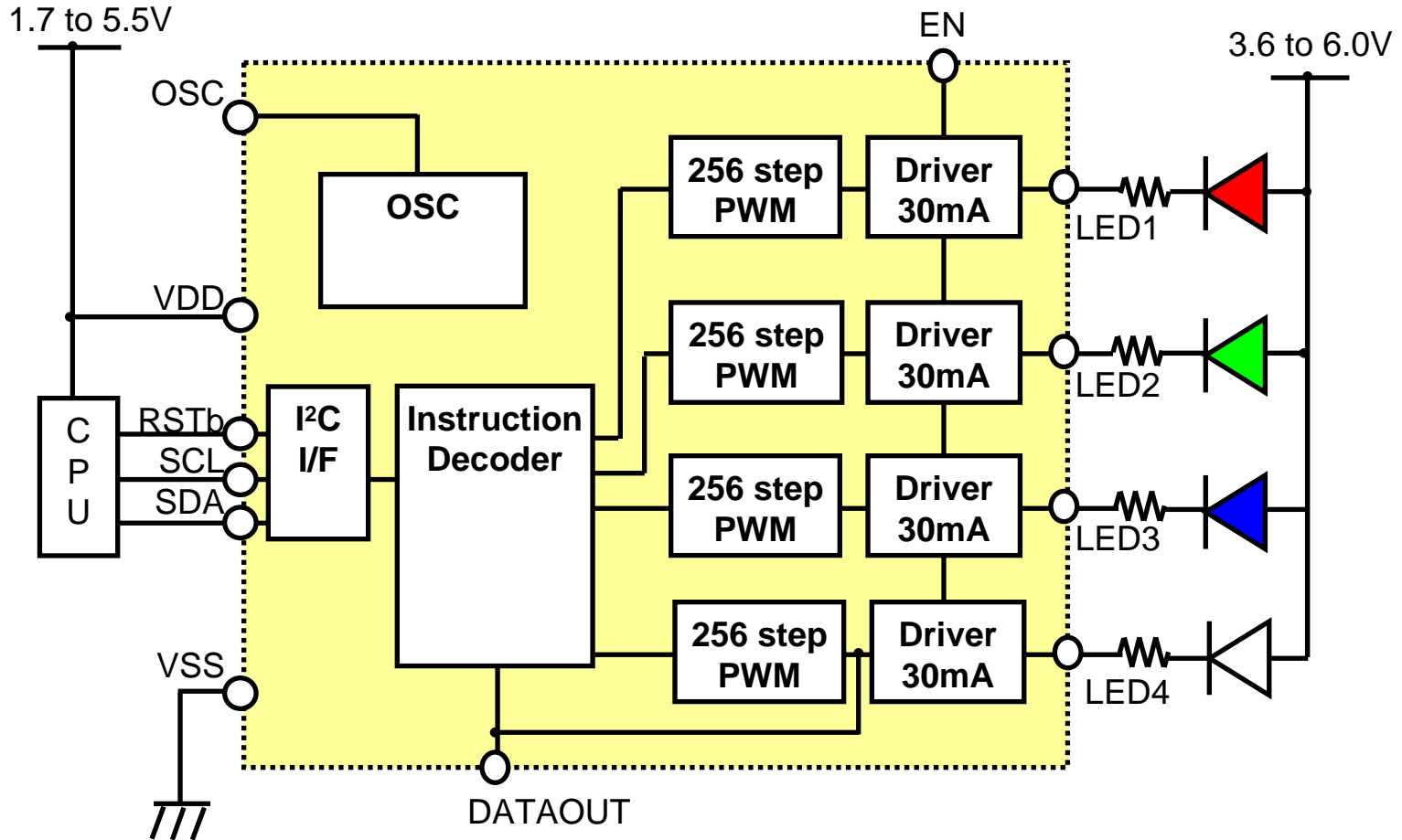

Multi Device Control

Two or more NJU6062 can be controlled in one I²C address. The DATAOUT terminal is connected with the RSTb terminal, and the in possible multi device control by assigning an original address in each device at initial setup.

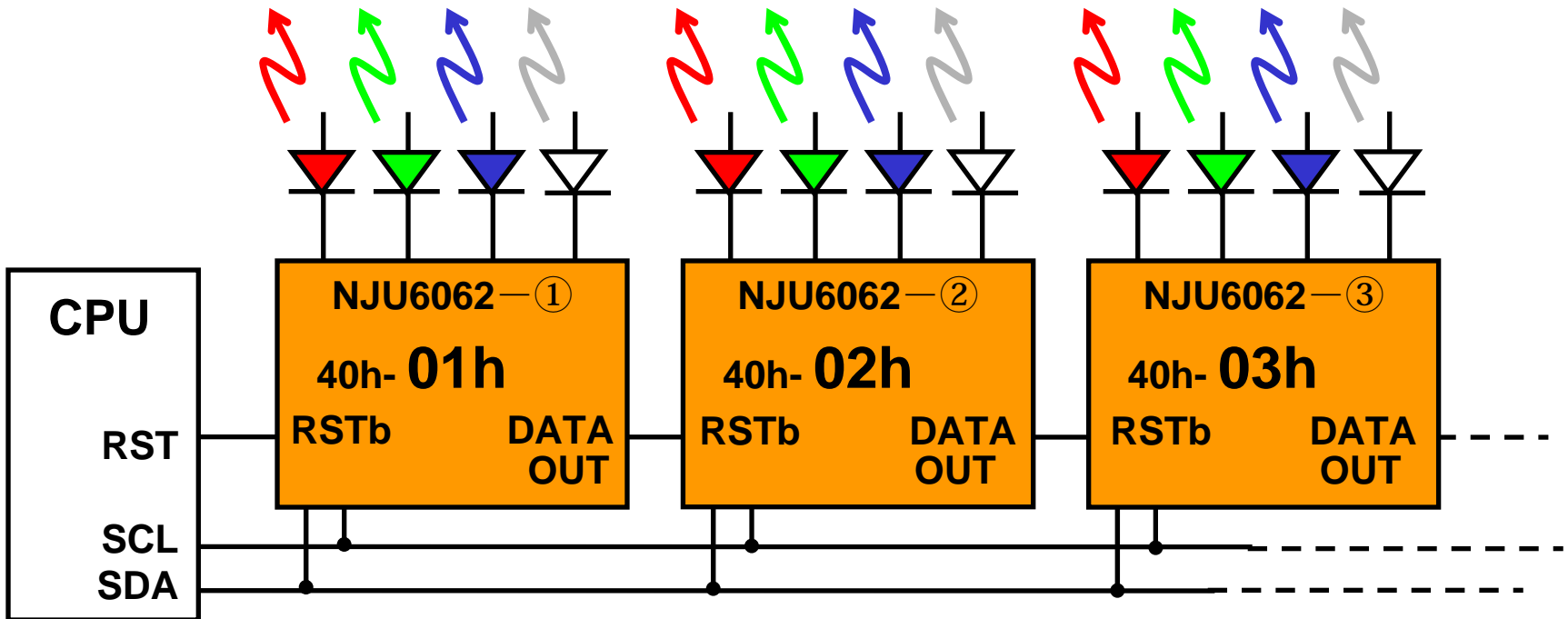

PWM output

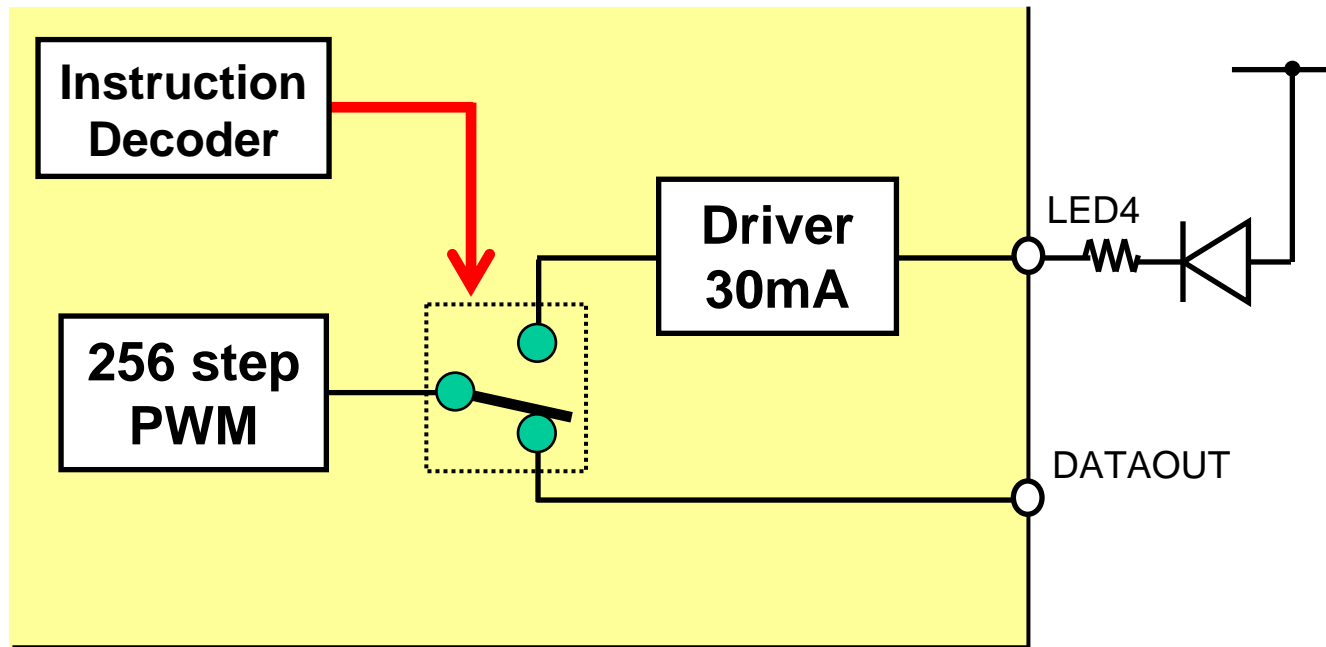

The PWM signal of LED4 can be output to the DATAOUT terminal by switching by the instruction.

The PWM signal can be supplied to an outside circuit (LCD backlight control and DC motor control e.t.c.)

NJU6061 NJU6062 Package

**Non lead type small package
Easy insert application.**



Illumination



Audio



Cellular Phone

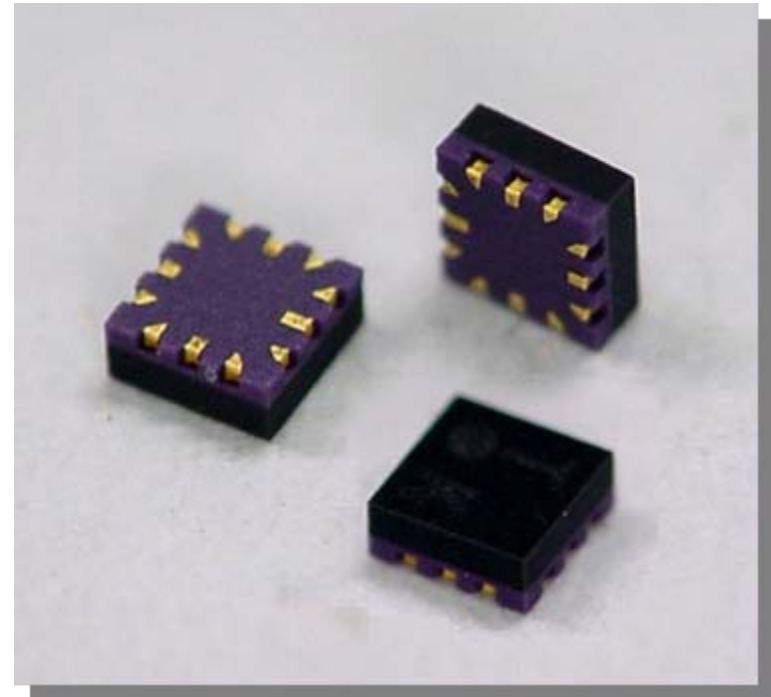

FFP12 (2.0x2.0x0.85mm)

Have Lead type package SSOP14

Reproduced with kind permission of

New Japan Radio Co., Ltd.

RGB LED Controller Driver

■ GENERAL DESCRIPTION

The **NJU6061** is an RGB LED driver with PWM control. It contains PWM (pulse width modulation) controller, LED drivers, 8-bit serial interface, etc. Each of the R (red), G (green) and B (blue) outputs produces 128 levels individually so that the RGB LED emits full color. It features a programmable sweep function, which can change LED color smoothly reducing CPU load. It requires only four external components such as three resistors for LED current adjustment and the one for oscillation, which enables the **NJU6061** to save PCB space. The **NJU6061** is suited for a large number of applications such as cellular phones, car stereo sets, household appliances, illumination equipment, etc.

■ FEATURES

- Controls R, G and B LED Individually ($I_{LED}=30mA \times 3$ outputs)
- Built-in PWM Luminance Control (Internal 128 steps \times 3)
- Built-in MPU Interface Circuit
- Cascade connection
- Programmable Function
- Built-in Oscillation Circuit
- Operating Voltage : 2.4V to 5.5V
- Package : FFP12, SSOP14
- CMOS Technology

■ BLOCK DIAGRAM

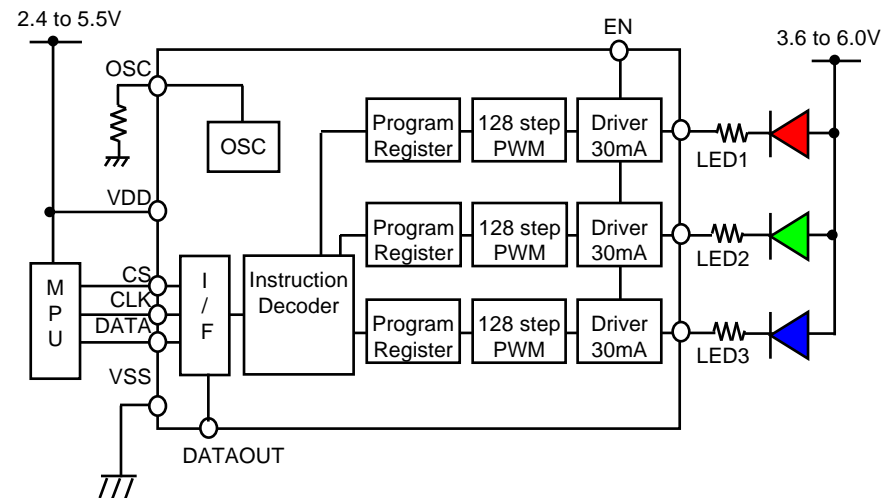

RGB LED Controller Driver

■ GENERAL DESCRIPTION

The **NJU6062** is an RGB LED driver with PWM control. It contains PWM (pulse width modulation) controller, LED drivers, I2C interface, etc. Each of the R (red), G (green) and B (blue) outputs produces 256 levels individually so that the RGB LED emits full color. It requires only four external components such as fore resistors for LED current adjustment and the one for oscillation, which enables the **NJU6062** to save PCB space. The **NJU6062** is suited for a large number of applications such as cellular phones, car stereo sets, household appliances, illumination equipment, etc.

■ FEATURES

- Controls R, G and B LED Individually ($I_{LED}=30\text{mA} \times 4$ outputs)
- Built-in PWM Luminance Control (256 steps \times 4)
- Built-in MPU Interface Circuit
- Built-in Oscillation Circuit
- Operating Voltage : 1.7V to 5.5V
- Package : FFP12, SSOP14
- CMOS Technology

■ BLOCK DIAGRAM

